



THE OFFICIAL VOICE OF GP-4 BUILDERS ALL OVER THE WORLD

VOLUME 19

MARCH - APRIL 1998



Jackie Yoder with his GP-4 at this years Sun N' Fun

I caught up with Jackie Yoder this year at the Sun N' Fun Fly-in down in Florida. He's a great guy to talk. There never has been time that I haven't walked away a little bit smarter, especially when it comes to the GP-4.

This time Jackie gave me the nickel tour of his "GP-4 Convertible". He deviated from the standard mount-

ing system. He incorporated a rail that was mounted on inside and forward (Photo #1). He did this so he could slightly scallop out the upper longeron for some additional width right at the shoulder area (Photo #2). When Jackie flew with George in the prototype he thought it was just a little bit tight.

I also didn't see any type of handle

on the outside of the canopy where one could use to slide it open. Jackie has incorporated an offset / eccentric like cam inside the fuselage that pushes the canopy about 5/8". He actuates the cam with an allen (Hex) wrench through the side of the fuselage (Photo #3).

Photos #5 through #8 and #10 show just how easy it is to remove

1

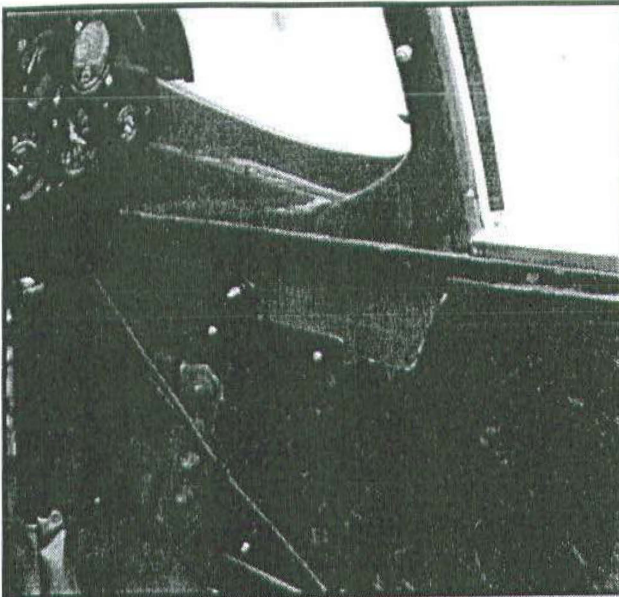

2

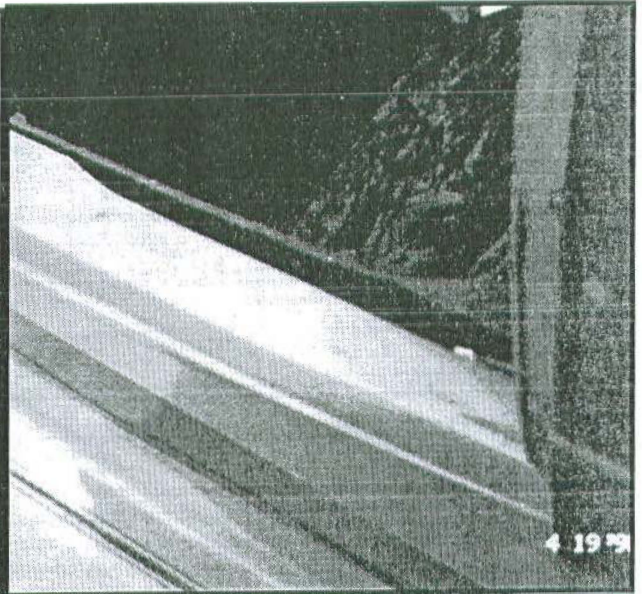

3

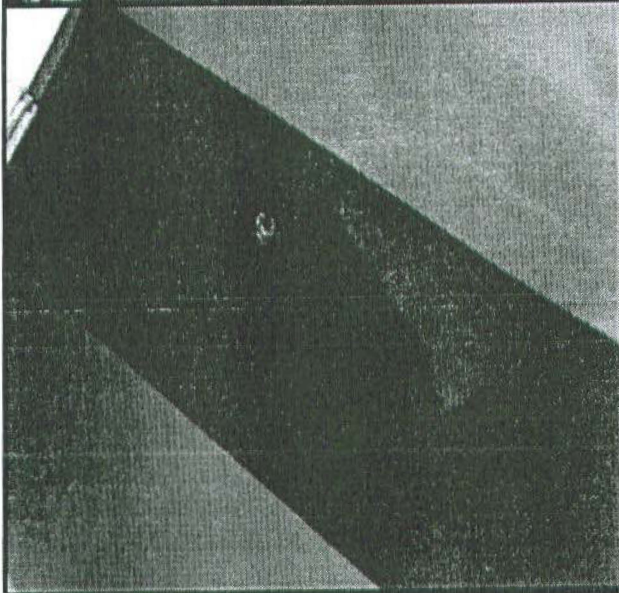

4

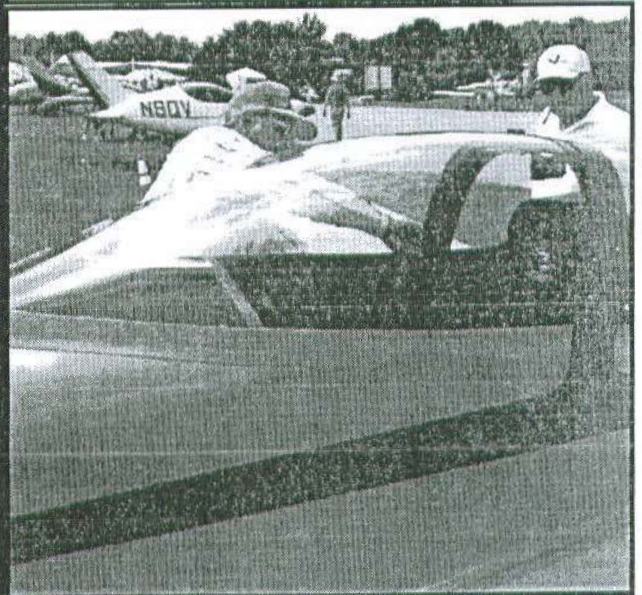

5

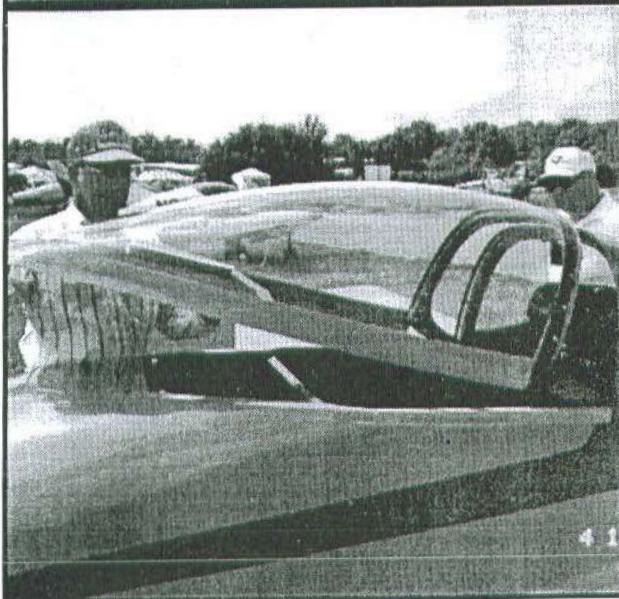

6

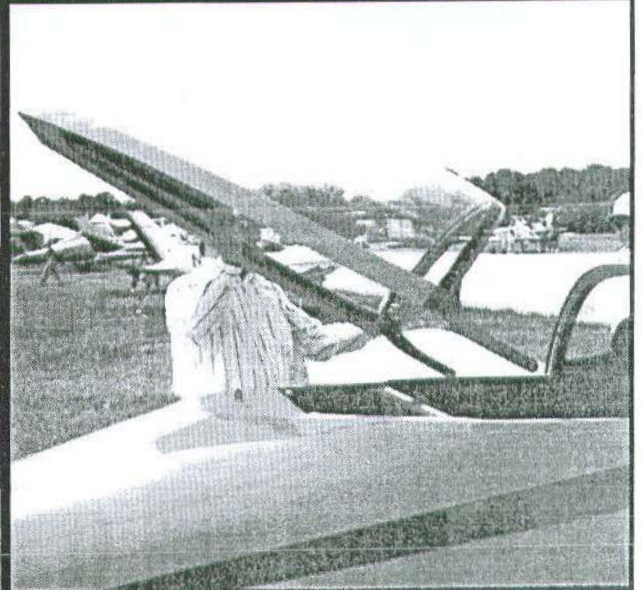

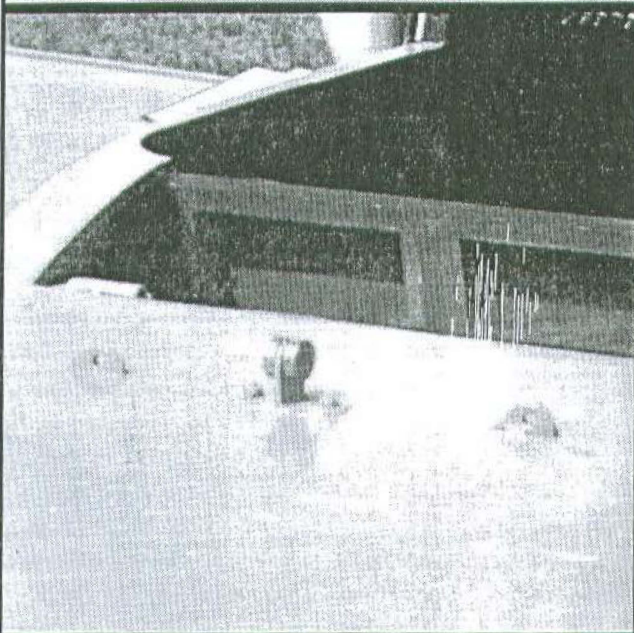
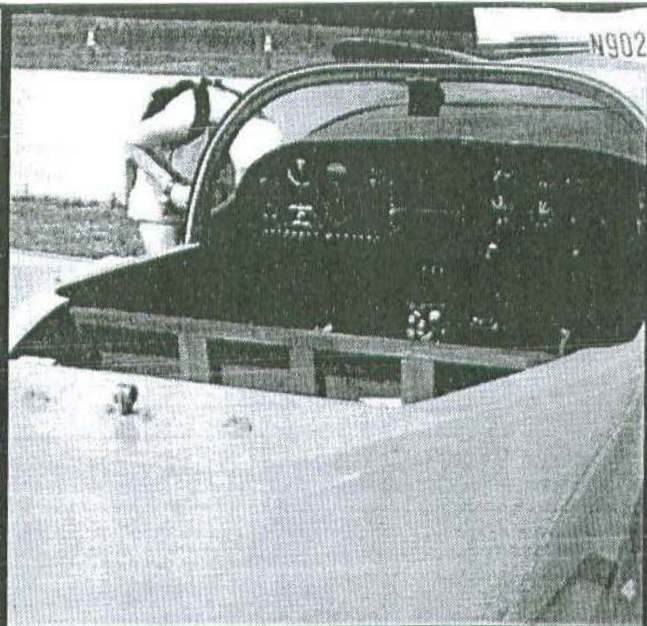
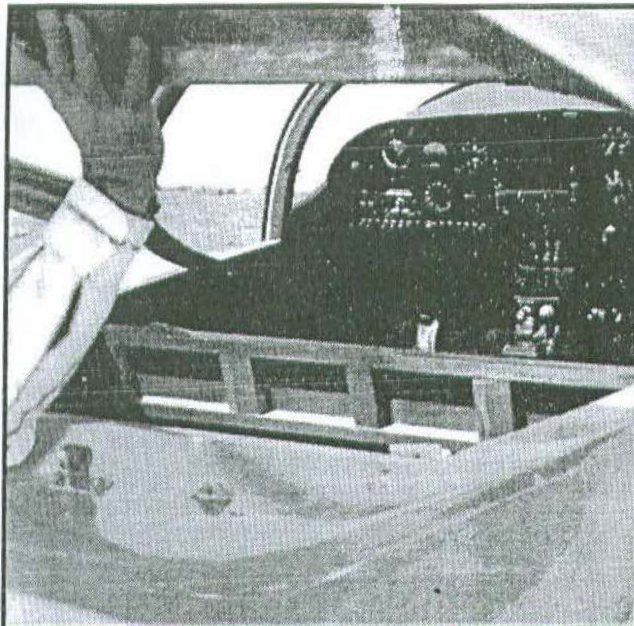

the canopy. Jackie said this was particularly handy when loading all the supplies for the Sun N' Fun Trip. Photo #9 shows the rear bearing assembly pedestal. This slides into a 1" square aluminum tube that is mounted to the canopy.

Jackie says he'll do up some more detailed sketch(s) for a future issue of GP4BFN.

Spud Spornitz

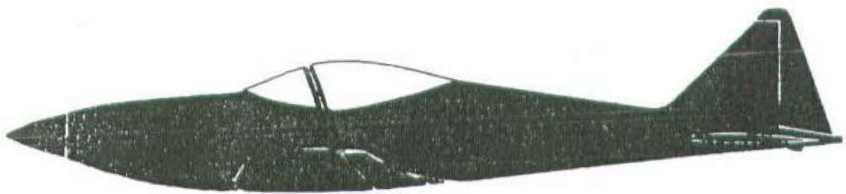

A SCARFER AND GLUING FIXTURE TIP FROM BOB FOSTER

Dear Spud,

During April, 1997, I threw in with you GP-4 builders at the #350 level. I hastily assembled my work table, made the fuselage layout, and by mid-May had both sides assembled but was not happy with the results. Fortunately I was called away on other matters until Oshkosh when I flew my 172 there for 5 wonderful days. While there I discussed my project with another GP-4 builder, and his comment was, "If you're not happy with it, do it over, I do."

So when I returned to Oroville, California by way of Arkansas, Oklahoma, New Mexico, and Southern California, I sawed both side assemblies apart, routed and scraped all the glue from the wood. In doing so I was able to analyze the problem areas. Some of the glue joints I was concerned about were, as I thought, partly dry due to the T-88 being absorbed into the more porous end grain of the spruce after fit up. During the re-assembly I applied a coat of T-88 to the end grain, let it set awhile, then added another layer to both surfaces prior to fit up. This time I assembled each side in section's which worked better for glue pot-life, good fit ups, and less anguish.

Another problem was mismatch at the same joints in both right and left assemblies - the worst ease being approximately 0.030 of an inch. I found this to be a result of variations in the plywood top of the work table. Builders should be aware that when they buy plywood that has been sanded on both sides, it does not mean that the sides have necessarily been sanded **equally** on both sides. I had to go back and level the surface by shimming and adding more screws. I am now happy with both my glued assemblies.

I have included two drawings of assembly fixtures that worked well for me. In the first drawing, I show the use of screws on the canopy bow jig which seemed less awkward than clamps. I removed the top screw, indexed the glued parts against the bottom screw, then inserted and torqued the top screw. The glue pot-life allowed time enough for a half lay-up at a time. In the second drawing I show the use of a hand-held electric planer for scarfing plywood. It also worked well.

I now have a couple of hundred hours on the project with the fuselage and horizontal stabilizer ready to skin. The metal parts for the fuselage are in jigs ready to weld. Practice is in order. Fun project, huh?

Our EAA Chapter 1112, Oroville, California, has a fly-in breakfast on the 3rd Saturday of each month from 8:00 to 10:00 am. In the hangar at the northeast corner of the airport. During 1998 we will have "after breakfast" programs with such practical topics as: how to make sheet metal parts, gas welding, riveting, etc. For information about breakfast or the scheduled programs, call Bob Foster (530) 589-4624 or Terry Hodges (530) 533-0698.

Chapter 1112 will host two fly-ins at the Oroville airport this year:

May 1-3 * The annual Starduster Fly-in will feature home-builts of all types in addition to Stardusters. Entertainment and refreshments will be provided.

June 21 -24 * An Aluminum Overcast will feature a B-17 arriving at 5:00 p.m. on Sunday. Rides will be given Monday through Wednesday. There will be home

builts, warbirds, radio-controlled models, classic cars and antique motorcycles as well as other entertainment and refreshments. Sunday evening will feature spaghetti feed.

Readers may also be interested in the first annual West Coast Fly-in (equal to Sun N' Fun) which will be held at Castle AFB, Atwater, California, on September 25-27. Volunteers are needed during the event. To sign up to help or chair a function, call Ray Bell at (530) 345-3453 or Elizabeth Bailes at (530) 675-0730.

Bob Foster
Oroville, CA
Hitech@sunset.net

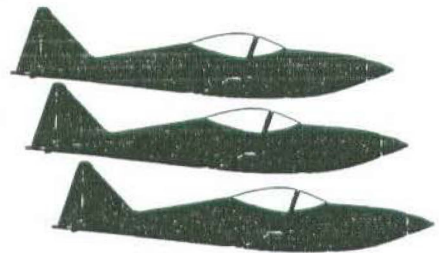

SCARFING PLYWOOD USING AN ELECTRIC HAND PLANER

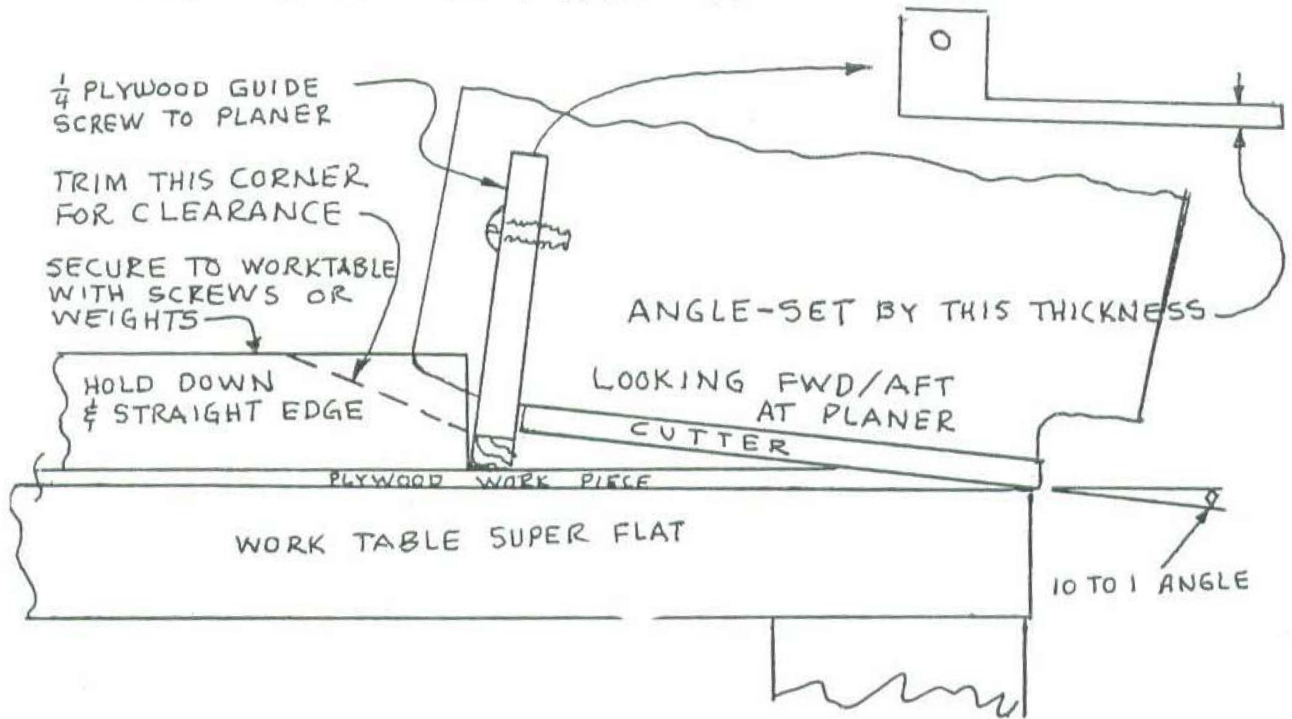

GLUEING FIXTURE FOR CANOPY BOW

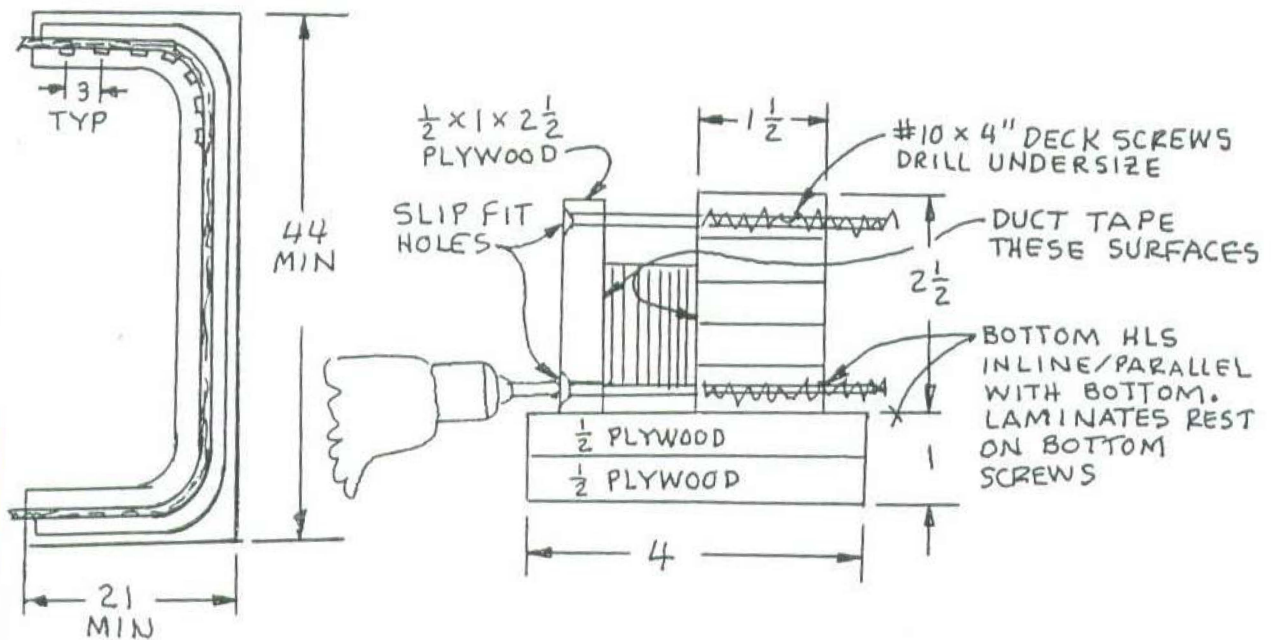

GEORGE'S CORNER



Fellow GP-4 builders,

Perhaps you have heard about El Nino washing away California homes in mud slides, etc. Its also dampened our flying time here on the west coast. Two very nice gentlemen had traveled a long way for a demo ride, but the rain was relentless with low ceilings and sheets of rain. Yes, they sat in the seats and we talked GP-4, but I felt their disappointment as my time was running out and the rain continued.

Landing lights:

From time to time I've been asked if a landing light can be installed in the wings leading edge out-board of the wing tank. The 63 series airfoil we use is very critical to a roughness factor. Any small bumps or seams will spoil laminar flow so we try to keep the first 30% of the wing as clean as possible.

Aileron trim:

Of all the movable control surfaces the ailerons are the most vulnerable to flutter. If you have to install a fixed tab for trim, make sure its very stiff. About .060 2024 T-3 aluminum. Not more than 1 1/4" in chord. I do not recommend any movable aileron tabs such as a MAAC trim unit. It

will add weight aft of the hinge line and any play in the trim unit could induce flutter into the aileron. An adjustable bungee attached to the aileron pushrod is a much better way to control aileron trim on the GP-4. YES....I know we use a MAC trim on the elevator, but were dealing with a smaller compact unit. It's very stiff torsionally. Note the very rugged torque tube that connects the two elevators. There is no play in this unit to start any attenuation.

Varnishing the interiors:

I like Varathane to seal the inside wood parts of the GP-4. It has a mildew proof agent and leaves a very hard finish as a sealer. It is easy to brush on and it should be brushed for better penetration. You thin the first 10% with paint thinner (mineral spirits) and the 2nd coat can follow (unthinned) right after. The 3rd coat is also unthinned and should be applied when the 2nd coat is almost dry to the touch, but just slightly tacky. All of the ply skins that glue on last must have the ribs and spar outlines marked so you don't pre-varnish over the areas where the assembly glue has to go. I brushed the Varathane up to 1/4" of the glue line rather than mask the glue area. Any Varathane that

might cover over into the glue area should be sanded off prior to attaching the skin. When applying the glue to the skin be liberal and cover or spread over any raw wood area so that all of the interior is sealed. Whatever sealer you use it should be high gloss. A gallon should do should do it for your total interior.

Steps in covering a control surface: Aileron, etc.

1. Cut 1/16" ply skins to fit, top and bottom.
2. Drill a 1/4" hole through the skin into the spar at each end. About 3/8" deep.
3. Insert a 1/4" dowel about 1/2 long through the skin into the spar with a touch of glue in the spar only. You can now position each skin in exactly the same place when removed.
4. Remove one skin and mark the other skin around the ribs and spars. Remove and repeat to the other skin.
5. Glue and staple 1st skin in place and after the glue dries, varnish ribs, skin and spars.
6. Varnish the other skin up next to the glue areas. When dry your ready to glue and staple the skin in place.

I hope this clears up the ply attachment process. You can apply the 6 steps for wings, tail and the fuselage. Don't forget to staple through a light piece of cardboard or poster board and always pull the when dry. I use a sharpened flat point screwdriver. Slip under one corner of the staple and lift up. I then use a pair of dike cutters and grab the staple and rotate the dikes pulling the staple.

Regards to All.

George



The Classifieds

For Sale: New Hydraulic Gear Plans Upgrade. Convert your GP-4 manual landing gear system to hydraulic - electric system. Complete with emergency back up system. (Note: System must be installed prior to wing skinning!, no retro-fits) Complete print package for \$150.00 Mail your checks to: George Pereira 3741 El Ricon Way, Sacramento, California 95864 phone (916) 483-3004

For Sale: Pre-fabricated composite components for GP-4. Cowling , exhaust blisters, inlet ramps, tailcone . Complete four-piece package. Call or E-mail for current pricing. Shipment will be sent "Freight Collect" - Jake Jackson - Rio Linda, CA (916) 992-0608 E-mail I7200@aol.com

For Sale: Quality custom fabricated metal components for your GP-4. See GP4BFN issue #4 for complete component listings and pricing. Please allow generous time allowances for your orders. Darry Capps, 813 Hoyer Road, Newman, California (209) 862-2707

Back Issues: We have all of the GP-4 back issues (1996 and back) available for \$3.00 each. Mail your checks to Bill Spornitz - 1112 East Layton Drive - Olathe, KS 6061-2936

Wanted: Looking for a GP-4 project that is "well under way" through "close to being finished". Will consider all projects. Contact me at (503) 646-5276 or by mail at Edward Mitchell, 13835 S.W. Devonshire, Beaverton, OR 97005

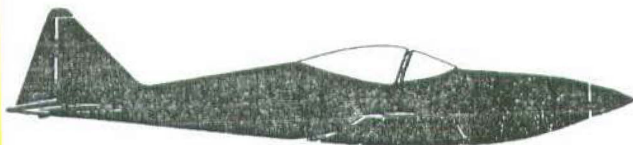

Subscribers Information Center

GP-4 Builders & Flyers Newsletter (GP4BFN) is currently published Bimonthly at a rate of \$3.00 per issue/\$18.00 a year in U.S. \$3.33 per issue/\$20.00 a yr. in Canada, Alaska & Mexico. \$4.83 per issue/\$29.00 a yr. (U.S. funds) per 6 issues to foreign subscribers. Send remittance to: GP4BFN, 1112 Layton Drive, Olathe, Kansas 66061. **PLEASE MAKE CHECKS PAYABLE TO: BILL SPORNITZ**

Ideas and opinions expressed in GP4BFN are solely those of the individual submitter. This information is for educational purposes only! Application of these ideas and/or suggestions contained in GP4BFN are the sole responsibility of the experimental aircraft builder at their own risk, which could result in builder/pilot personal injury or death. GP4BFN, George Pereira, Osprey Aircraft do not imply or suggest in any way their usage.

Letters, Pictures and computer supplied data submitted to GP4BFN are subject to final screening by GP4BFN / Bill "Spud" Spornitz and may be restricted, deleted or revised. Material returned by request only.

Classified advertising; (non-commercial) for current subscribers may place an ad of 50 words or less for \$6.00 per issue, with one photo an additional \$14.00. Back issues of "GP-4 Builders & Flyers Newsletter", back issues are available for \$3.00 each.

The use of "Lycoming", "Hartzell" and/or "Osprey Aircraft" by GP4BFN is for the sole purpose of application and description only and is not intended to infer or imply a direct connection between GP4BFN, Lycoming, Hartzell or Osprey Aircraft.

913-764-5118

E-MAIL BSPORNITZ@AOL.COM

News Flash!!! Yoder changes GP-4 into a VP-2!!!!!!

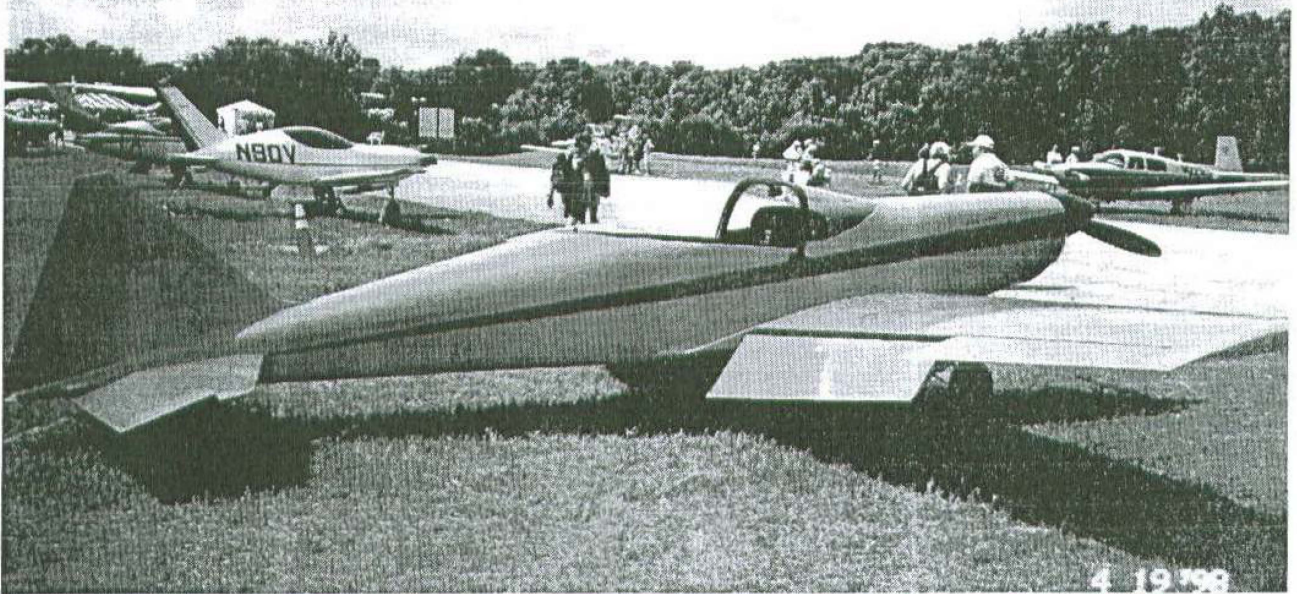

Not Really! Learn more about Jackie Yoder's "Convertible" GP-4 modification inside....



**1112 EAST LAYTON DRIVE
OLATHE, KANSAS 66061**



NEWS FOR CRAFTSMEN OF FAST WOODEN AIRCRAFT!