

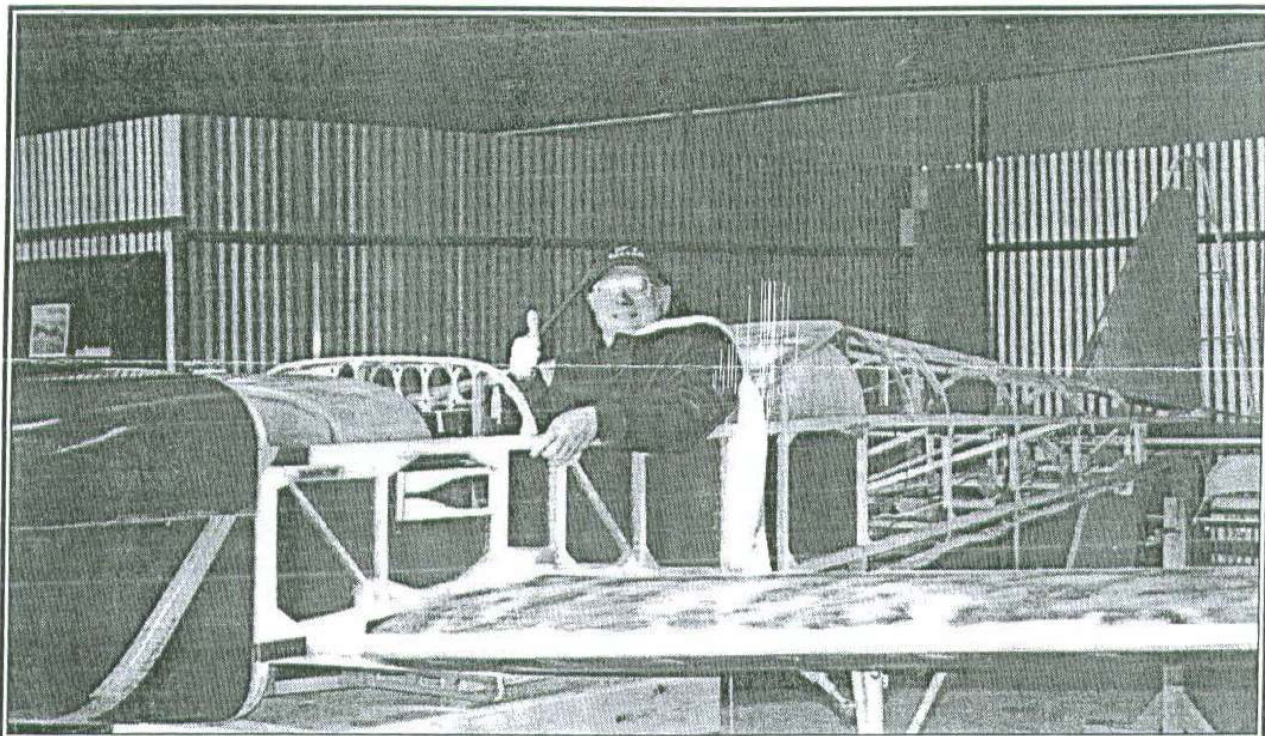

THE OFFICIAL VOICE OF GP-4 BUILDERS ALL OVER THE WORLD

VOLUME 20

MAY - JUNE 1998



C.J. Reinhart of Roanoke, Texas in his GP-4

Hello Spud and our GP-4 builders, I've included some pictures of the cradle I made to fit around the center of the spar. One-person can flip the wing over – or up on the leading edge. It balances very well – I've left it on edge as long as two weeks with no other support. Made from 3/4" plywood, 2 pieces of 2" X 12" and one piece of 2" X 6". Very simple and worth its weight in gold!

When we skinned the top and bottom of the wing we used 1/2" nylon strapping tape for the nailing (stapling) strips I purchased it for \$10.00. Cut it, tape it on, and staple through it. then, let it dry. Then pry the staples out with a sharp screwdriver & pliers. No wood damage – a few dents, but they all get covered up with glass deck cloth.

The wing is now complete except for foam tips. I used Darry Capp's molds for the plastic lenses – 2 each for left and right. The wing has the 1 oz. deck cloth on it. I used West System Epoxy – these guys have been in the wood and glass business for many, many years. I coated the inside of my fuel tanks with their chemical proof Pro Set

epoxy and did the final assembly with it. They have years of fuel and epoxy testing – Safety Poxy people had no fuel tests.

When I put the top skins on the flaps and ailerons. (To do this – and ensure everything fit) – I suggested you use the method that Tommy Walker showed me. Hook up the flaps and ailerons to their hinges. This ensures the spar and hinges all line up. Make a scaffold of 2" X 6" X 12' for each trailing edge so that the trailing edges of the flaps and ailerons lay flat (or will lay flat when skinned) against it. Mine had developed some minor warpage since I built them a year + ago. When I put all 3 hinges in place with pins, the trailing edge warps a little. – So I suppose others may have the same problem.

Once the trailing edge scaffold is in place – glue the skins once everything has been checked for good fit and square. Clamp on a 2" X 4" on each end of the bench to hold the outboard end of the 2" X 6". Brace the inboard edge of the 2" X 6"s – set the angle correctly with leveling wedges when you set it up. Then the trailing edge has a flat surface 12' long to ensure its straight, tip to center. Well, using this method, after both top and bottom skins are on – they fit up every time, all 3 holes, and the trailing edges are Straight!

Be sure you have 2 good, straight 2" X 6" X 12'. This project will take about two hours.

To this point of construction I have 1214 hours to date, which 188 hours in the stabilizer and elevators and 1026 in the wing assembly.

I then moved on to the fuselage in July of 1996. As you can see, its ready – almost to skin. Fin is on. Rudder complete – ready to skin, counterbalances made. Rudder pedals complete (Darry Capps) and attach hardware complete. Darry is working on my motor mount and nosewheel assembly. I took the fuselage out to begin leveling and measuring for the wing attach fittings. Once the fuselage is bolted on, I'll glue the stabilizer – that way it goes on square.

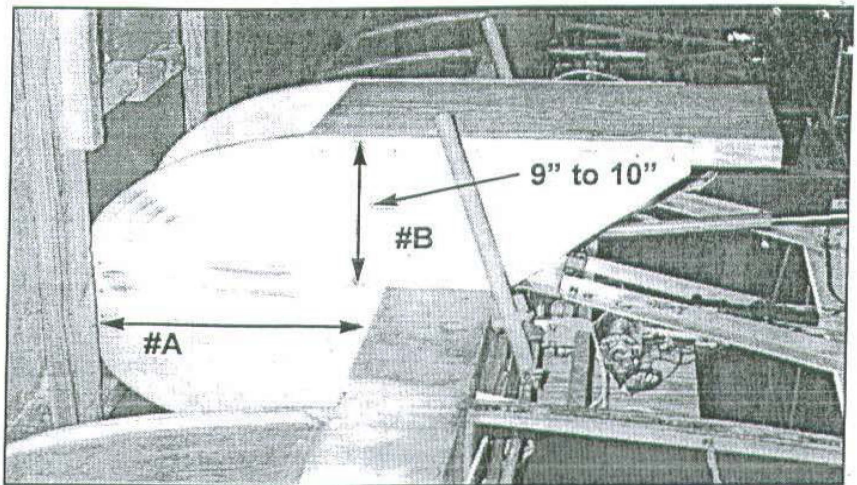

"A" Make long enough to clear leading edge with pine strips.
"B" Make long enough to clear tips when upside down.

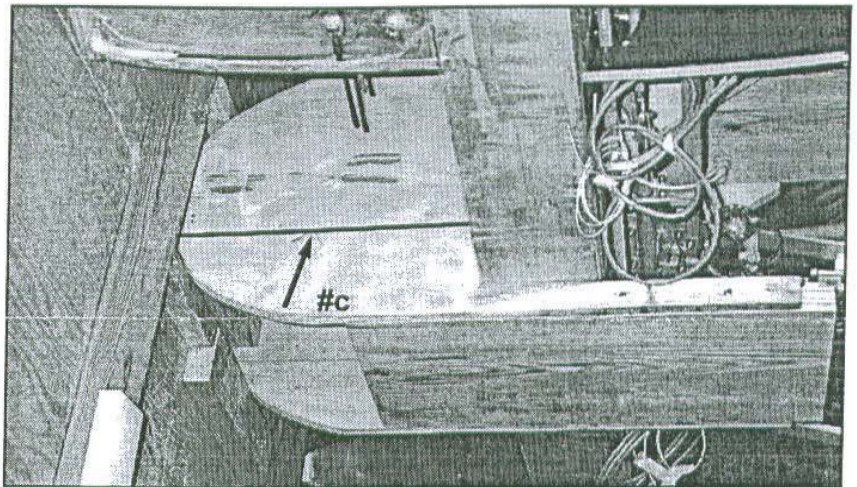

"C" is the chord line at this point on the spar.

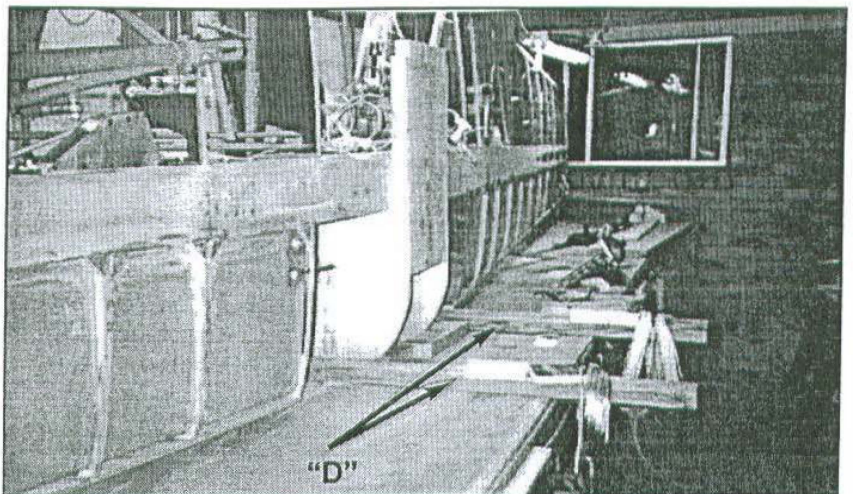

"D", I find these 2" X 6" overhangs MOST helpful.

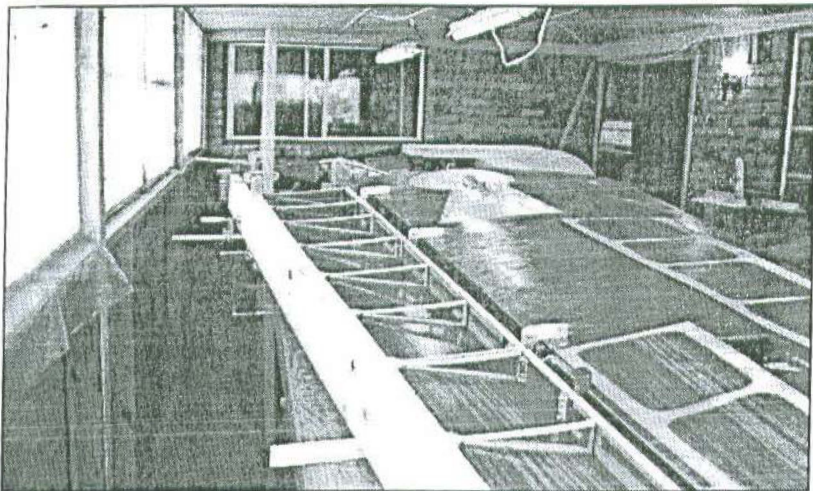

Note the 2 X 4's have migrated to the center of the work bench. Here's the reverse. Also, left cloth over wheel well.

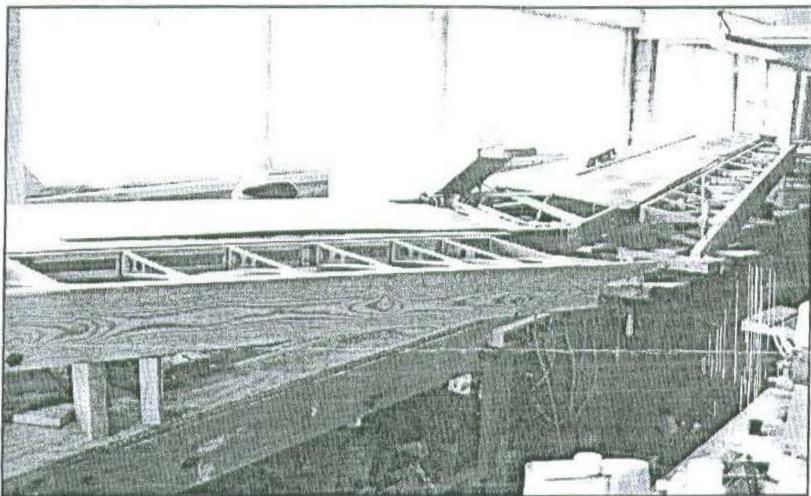

2 x4's are clamped to end of table and the use of leveling wedges and taper of the 2 X 6 ends.

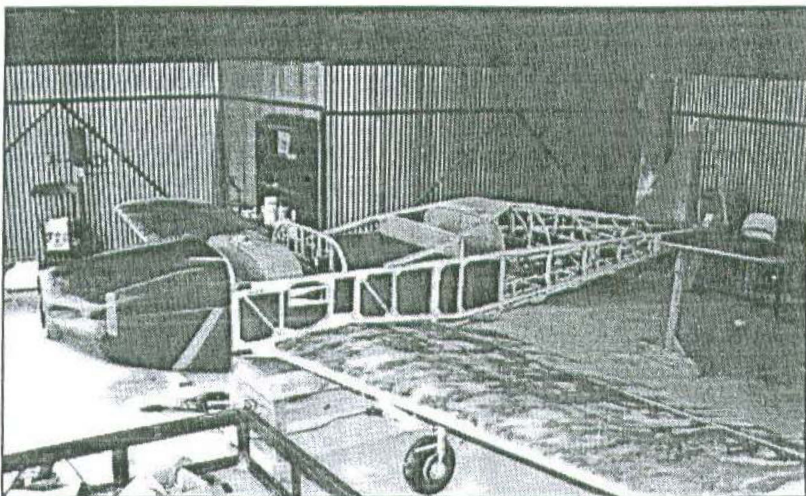

Final fit up before skinning.

Right now – when everything is leveled and up snug and eyeball straight – the measurement from the bottom of the fin skin on each side to a point on each spar is identical – not off by more than 1/32 to 1/64 of an inch.

I've had problems to solve, but nothing serious. I had the lower former at 55 1/2", about 3/4" too far forward and the fuselage wouldn't fit over the center of the rear spar joint. My main spar is 1/4" too thick to begin with – and I have about 1/8" to 1/4" more in the rear spar attach joint and the plans left something to interpret on where it actually goes – I really should have measured it – but the wing was 16 miles away in storage and I isn't think of it at the time.

I put a doubler in the backside and removed enough of the frontside to where it fits properly.

At this point we have three years of work and it looks very much like an airplane! In that three years we have 1947 hours of work. Darry Capps has done the metal work and Jake Jackson 's cowlng.

I still have a lot of work to do. i have to get the wing attach fitting in place and the holes drilled. Then skin the fuselage (except over the front cowl) – instrument panel - to firewall area. Build the canopy bows and canopy – bolt the nosewheel assembly, motormount on – wire all this stuff and put in the plumbing. Then put it together so the foam and glass fillets and prep for paint. Then on to the engine and prop, purchase and installation.

Early outlook is 1998 first flight, in late fall. Late estimate is 1999 – maybe Oshkosh.

In closing, I want to remind everyone to insure their projects for loss against weather or fire. All insurance companies will not cover the loss of a plane or project at home unless they are specifically listed in your policy coverage.

**C.J. Reinhart GP-4 #N233CR
Roanoke, Texas**

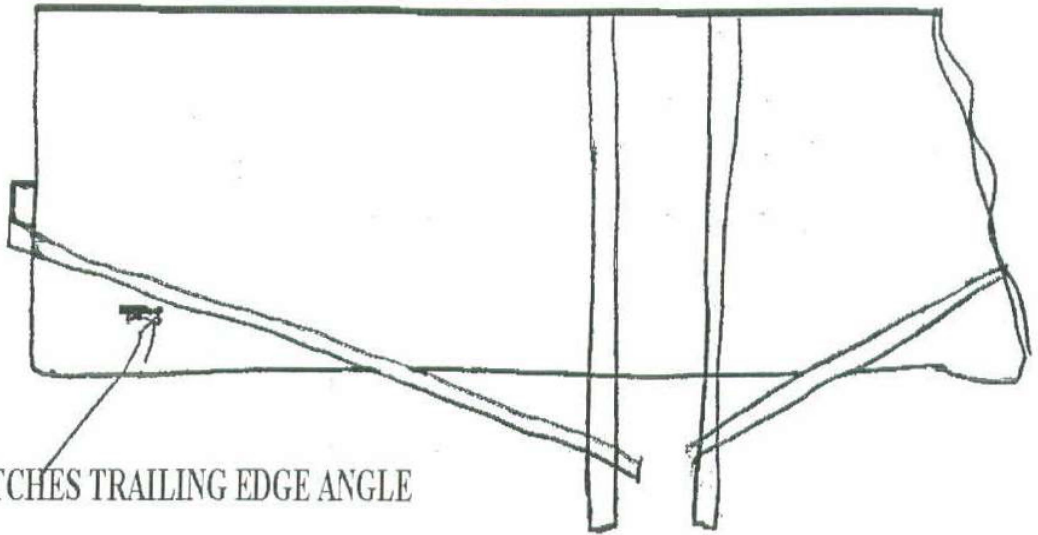

MATCHES TRAILING EDGE ANGLE

My 2" X 6' MOUNTED TO THE BENCH

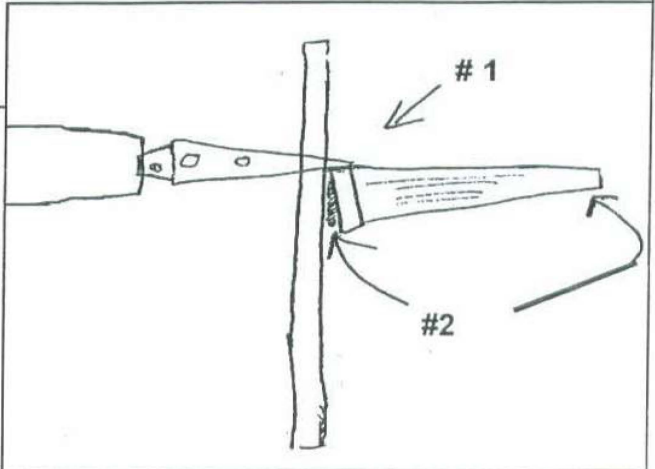
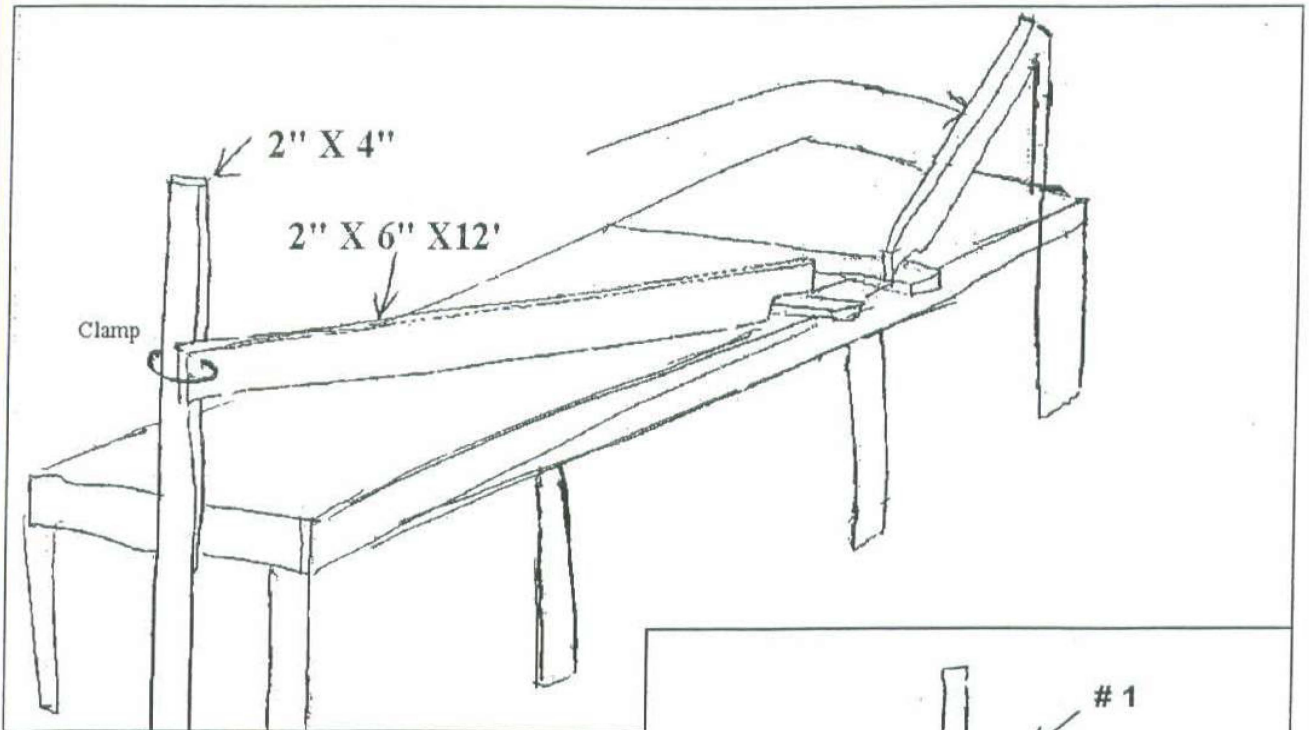

#1, Use a leveling wedge to tilt the 2 x 6 so that the top edge matches the angle of the bottom side of the trailing edges and then they'll lay flat.

#2, Use a leveling wedge to tilt the 2 x 6 out at the bottom. Makes a match to the bottom of the trailing edge both ends.

MULTICOM

Oshkosh 1998

We have the GP-4 builders and flyers meeting scheduled for **Saturday morning August 1st between 8:00 to 10:00 AM at the Homebuilders Headquarters Building area.** Ben Owen and his trusty staff have made a nice improvement to this meeting area. There will be a large two section tent with chairs, etc for our annual Oshkosh meeting. The Homebuilders Hdqtrs building is just southeast of the tower.

Oshkosh 98 banquet

Over the last eight years I've had the pleasure of putting on, what was first labeled the **Dragonfly dinner**, then it turned into the **Dragonfly - Quickie dinner**, then it grew to the **Dragonfly, Quickie and KR-2 Banquet** (130+ people) This year we'd like to invite the **GP-4, Osprey II and the Sonerai gang.** In that regards, if your a homebuilder and hungry, your welcome to come hoot it up for about three or four hours with a bunch of airplane nuts just like yourself (*Ain't America Great!!*). This years banquet sign will read....**The Dragonfly, Quickie, KR, GP-4, Osprey II, Sonerai at Etc, Etc, Banquet!!!**

The banquet is **Friday night** downtown at the Hilton at their convention center in the "Regatta Room". There will be a cash bar at 6:30 PM and dinner will be served at 8:00 PM with a short program (read that as a few jokes, some stories and few lies) to follow. The banquet does need to be **prepaid** at **Great Plains Aircraft Supply** (they are in one of the new blue buildings in the N.W. corner) booth no later than **High NOON on Friday.** See you all there!
Regards - Spudley

GEORGE'S CORNER



Fellow GP-4 builders,

I got an interesting phone call from Ernie Holmes last week. Ernie is from Massachusetts and a prolific builder. He built a very nice Osprey II and is now taxing his GP-4. The Osprey II is not exactly a good transition trainer for the GP-4 so Ernie got a ride in a two place Lancair. There were no rudder pedals in the ride side, so its questionable on how much good the right seat ride will help for a first test flight! I hope Ernie can get some time in a suitable transition aircraft or better yet find a well-qualified test pilot for the first few flights. You know when you stop and think about spending the time, money to build your dream ship you just have to be prudent in planning your test flight program. I am sure we will be hearing from Ernie and his white and gold trim GP-4.

I always get a few calls asking if I will make Oshkosh this year. I am sorry to say I am not able to get away this year. I hope there will be some GP-4's there this year. Please let Spud know if you plan to fly your GP-4 to the 98 convention.

Trim tabs:

In the last newsletter (volume #19), I suggested a trim system on the aileron pushrod rather than a movable tab on the aileron. This is to prevent flutter in the aileron assembly. If you attach a spring on each

side of the pushrod travel and are able to adjust the tension from the cockpit you have a trim system. The drawing herewith (next page) is representative of my trim on the prototype and it works well. You should try to get a motor that has a rpm range of about 300 to up to 600 rpm. It should be 12 volt, however if it's 24-volt permanent magnet it should run ok on 12 volts. There are lots of these motors available and following are some phone numbers you might call and ask for a catalog or tell them what you require. It must be a reversible type as most of them are. They reverse direction with a change of polarity. Surplus Center: 1-800-488-3407. Jerry Co. Inc. 1-708-475-8440 / fax 1-708-864-1589. And Servo Systems Co. 1-800-922-1103.

If you use a faster rpm, 600 or so use a 1/4 X 28 thread on the screw axle. If you're using 300 rpm or lower use a 1/4 X 24 thread. The tension springs are fairly light, perhaps a pound when stretched in a neutral range. Hardware store variety 3/8" coil and about 1/32 wire size. You can use a rocker switch on the center console or MAC has a combination pitch - roll switch that mounts on the stick grip.

Good luck with your trims systems.

Regards,

George

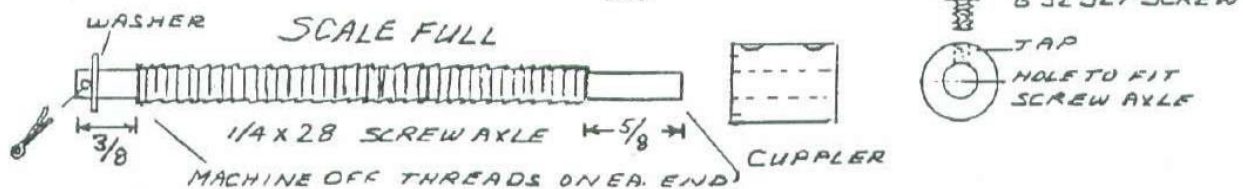
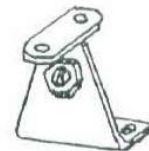
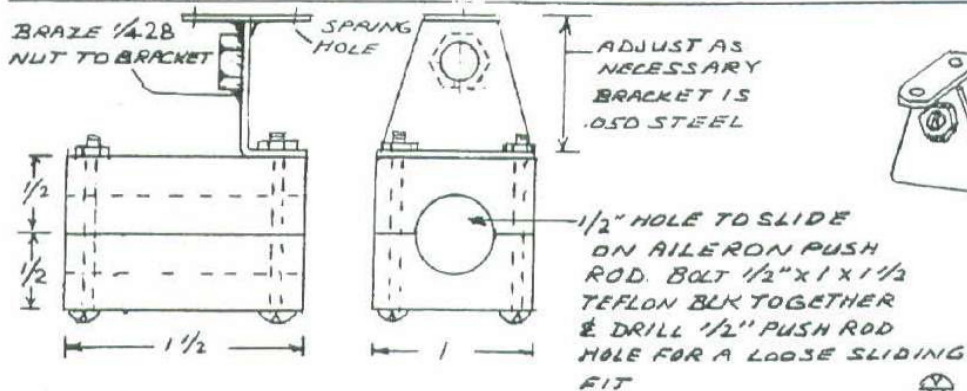
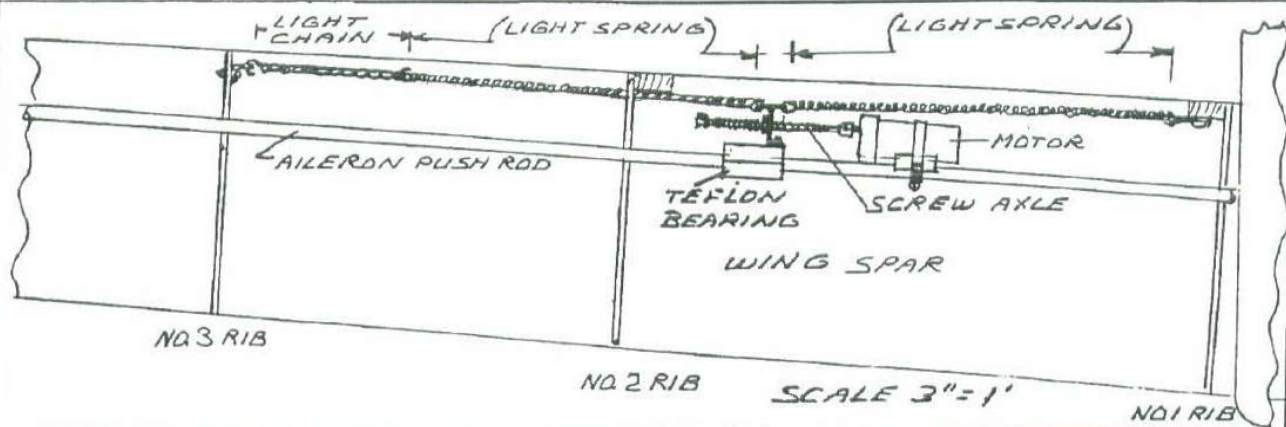

NOTE: WHEN THE 1/4 X 28 NUT RUNS OFF THE THREADS OF THE SCREW AXLE. SPRING TENSION WILL RE START IT WHEN ROTATION IS REVERSED

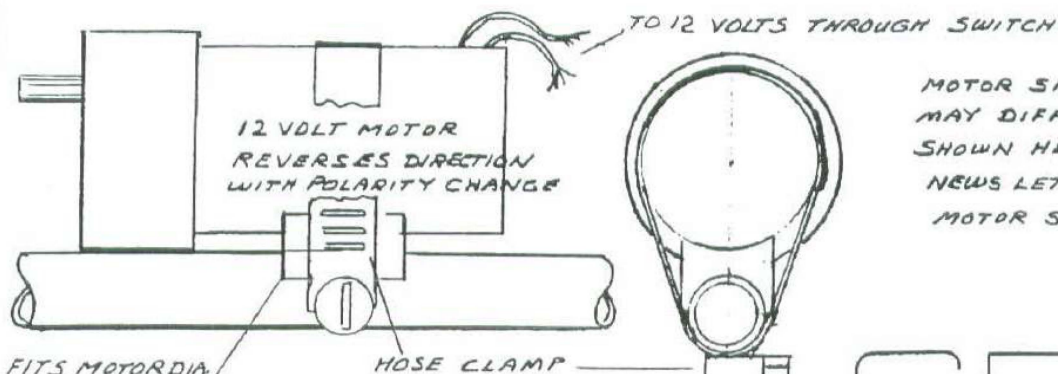

MOTOR SIZE & RPM MAY DIFFER FROM SHOWN HERE. SEE NEWS LETTER FOR MOTOR SOURCES.

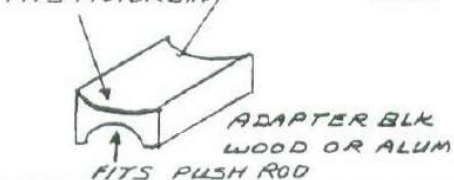

GP-4

AILERON TRIM
SCALE: 3"=1' & FULL
DESIGN: OSPREY AIRCRAFT

The Classifieds

For Sale: New Hydraulic Gear Plans Upgrade. Convert your GP-4 manual landing gear system to hydraulic - electric system. Complete with emergency back up system. (Note: System must be installed prior to wing skinning!, no retro-fits) Complete print package for \$150.00 Mail your checks to: George Pereira 3741 El Ricon Way, Sacramento, California 95864 phone (916) 483-3004

For Sale: Pre-fabricated composite components for GP-4. Cowling, exhaust blisters, inlet ramps, tailcone. Complete four-piece package. Call or E-mail for current pricing. Shipment will be sent "Freight Collect" - Jake Jackson - Rio Linda, CA (916) 992-0608 E-mail J7200@aol.com

For Sale: Quality custom fabricated metal components for your GP-4. See GP4BFN issue #4 for complete component listings and pricing. Please allow generous time allowances for your orders. Darry Capps, 813 Hoyer Road, Newman, California (209) 862-2707

Back Issues: We have all of the GP-4 back issues (1996 and back) available for \$3.00 each. Mail your checks to Bill Spornitz - 1112 East Layton Drive - Olathe, KS 6061-2936

Wanted: Looking for a GP-4 project that is "well under way" through "close to being finished". Will consider all projects. Contact me at (503) 646-5276 or by mail at Edward Mitchell, 13835 S.W. Devonshire, Beaverton, OR 97005

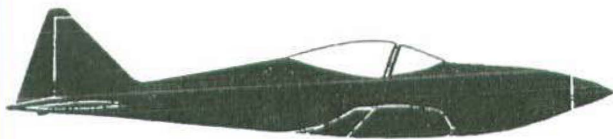

Subscribers Information Center

GP-4 Builders & Flyers Newsletter (GP4BFN) is currently published Bimonthly at a rate of \$3.00 per issue/\$18.00 a year in U.S. \$3.33 per issue/\$20.00 a yr. in Canada, Alaska & Mexico. \$4.83 per issue/\$29.00 a yr. (U.S. funds) per 6 issues to foreign subscribers. Send remittance to: GP4BFN, 1112 Layton Drive, Olathe, Kansas 66061. **PLEASE MAKE CHECKS PAYABLE TO: BILL SPORNITZ**

Ideas and opinions expressed in GP4BFN are solely those of the individual submitter. This information is for educational purposes only! Application of these ideas and/or suggestions contained in GP4BFN are the sole responsibility of the experimental aircraft builder at their own risk, which could result in builder/pilot personal injury or death. GP4BFN, George Pereira, Osprey Aircraft do not imply or suggest in any way their usage.

Letters, Pictures and computer supplied data submitted to GP4BFN are subject to final screening by GP4BFN / Bill "Spud" Spornitz and may be restricted, deleted or revised. Material returned by request only.

Classified advertising; (non-commercial) for current subscribers may place an ad of 50 words or less for \$6.00 per issue, with one photo an additional \$14.00. Back issues of "GP-4 Builders & Flyers Newsletter", back issues are available for \$3.00 each.

The use of "Lycoming", "Hartzell" and/or "Osprey Aircraft" by GP4BFN is for the sole purpose of application and description only and is not intended to infer or imply a direct connection between GP4BFN, Lycoming, Hartzell or Osprey Aircraft.

913-764-5118

E-MAIL BSPORNITZ@AOL.COM

Yoders at it again! Now he thinks it's a PICK-UP!!!!

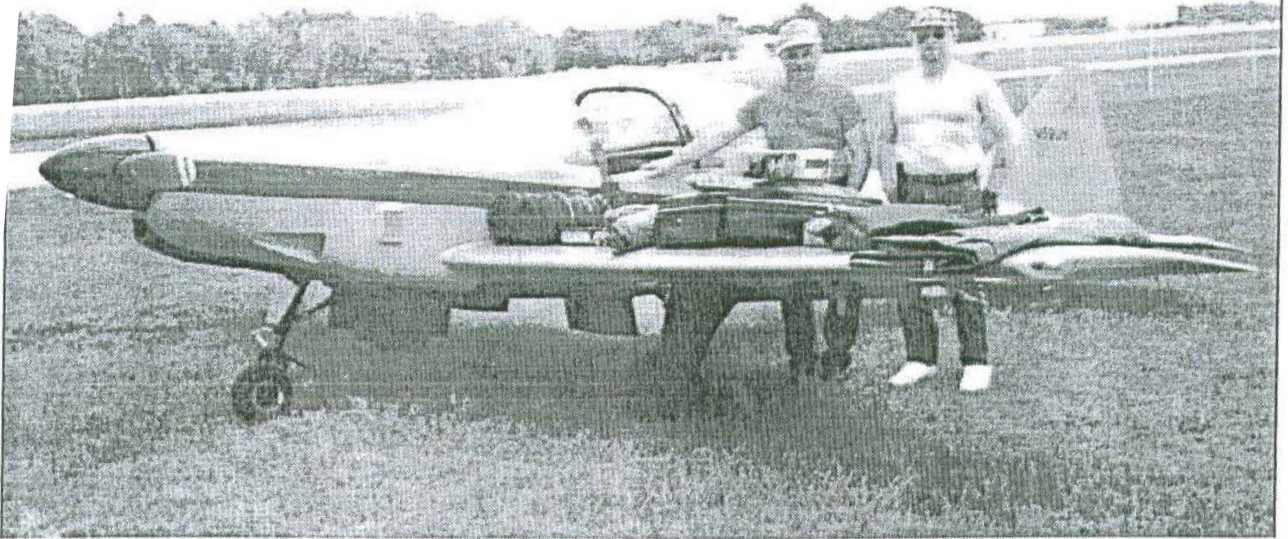

*Jackie Yoder & Jim Powell at this years Sun N' Fun and still within the C.G.
Looks like they had everything but the "Kitchen Sink"*



**1112 EAST LAYTON DRIVE
OLATHE, KANSAS 66061**

NEWS FOR CRAFTSMEN OF FAST WOODEN AIRCRAFT!